

MATSING[®]

LENS TECHNOLOGY ENABLED

MS-MBC-4-H4-12

Instruction Manual

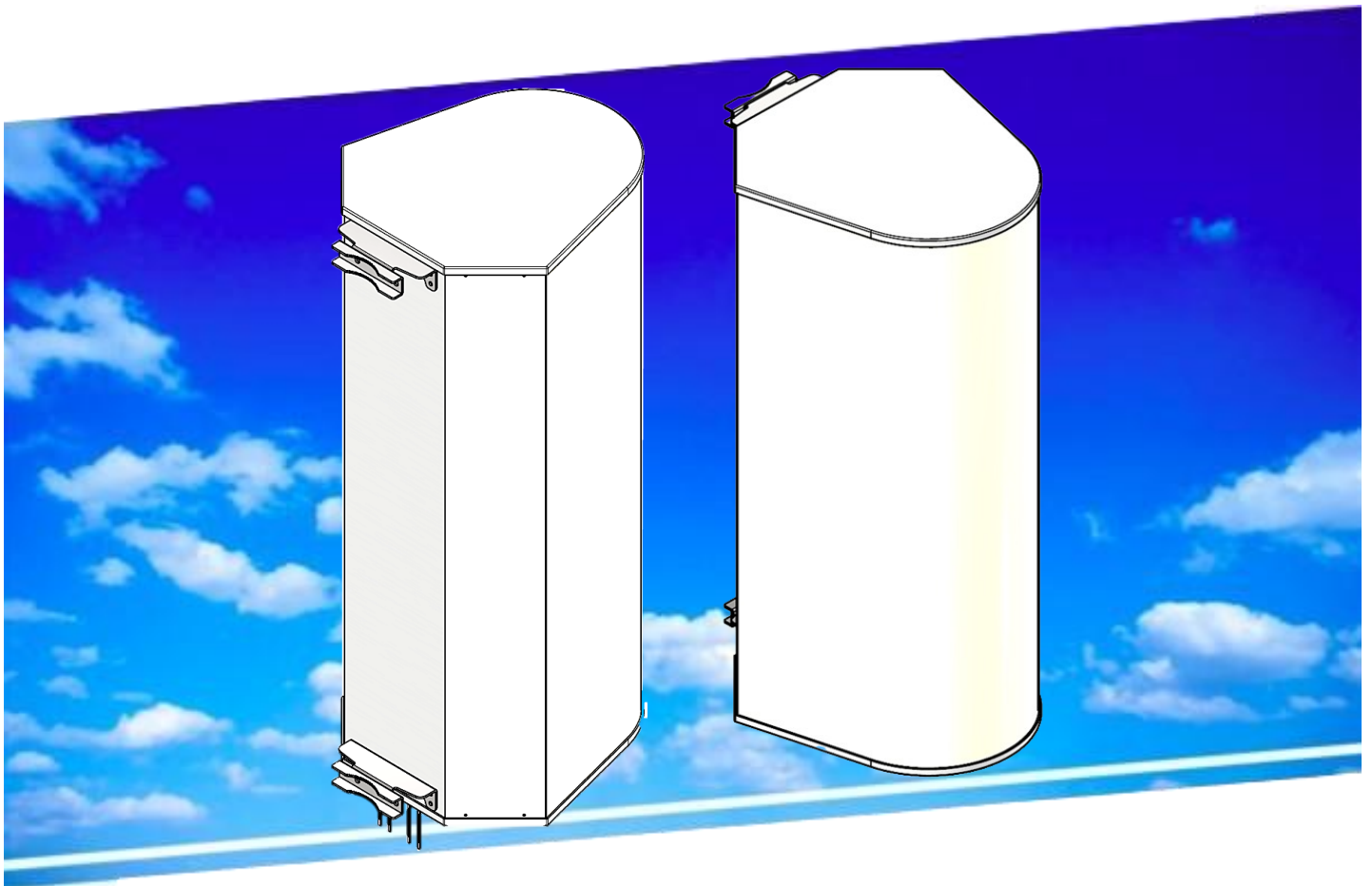

Table of Contents

1.00 Pattern diagram

- 1.10 Horizontal pattern
- 1.20 Vertical pattern

2.00 Beams and connectors

- 2.10 Plan view resultant beam layout
- 2.20 Connector port table
- 2.30 Connector detail
- 2.40 Connector layout

3.00 RET Operations and information

- 3.10 Example of serial numbers label reference
 - 3.11 Controller display
 - 3.12 Beam numbers and ports number display

4.00 Bracket installation

- 4.10 Bolts and nuts / Tools
 - 4.11 Bolts and nuts
 - 4.12 Bracket
- 4.20 Tools requirement
 - 4.21 Adjustable spanner
 - 4.22 M12 spanner
- 4.30 Bracket spacing and installation sample

Revision History:

<u>Date</u>	<u>Description</u>	<u>Rev By</u>	<u>Check By</u>	<u>Rev no</u>
06-Nov-2024	Initial Release	RL	Pavel	0
11-Nov-2024	Add RET operations/information	RL	Pavel	1

1.00 Pattern diagram

1.10 Horizontal pattern

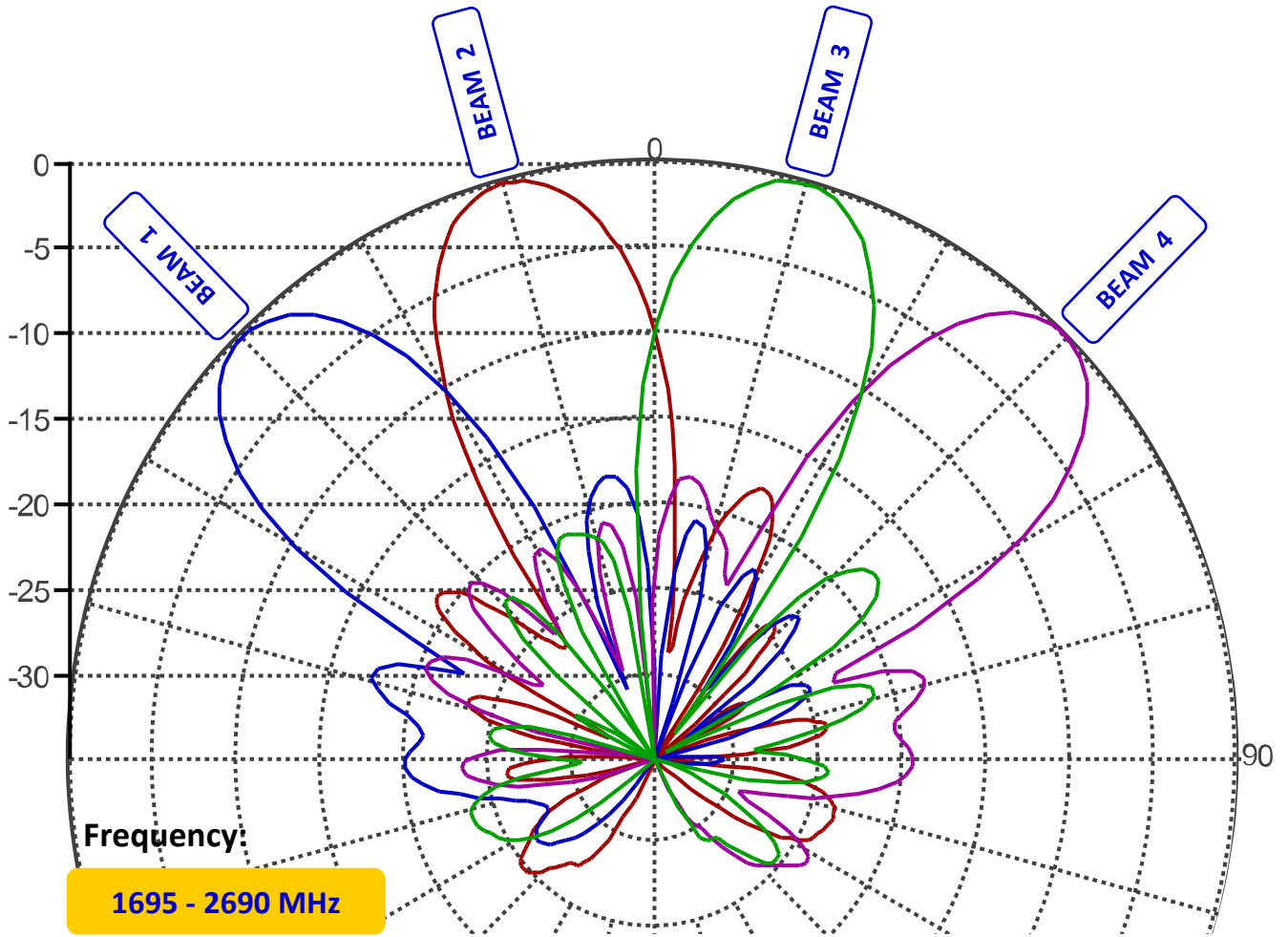

1.20 Vertical pattern

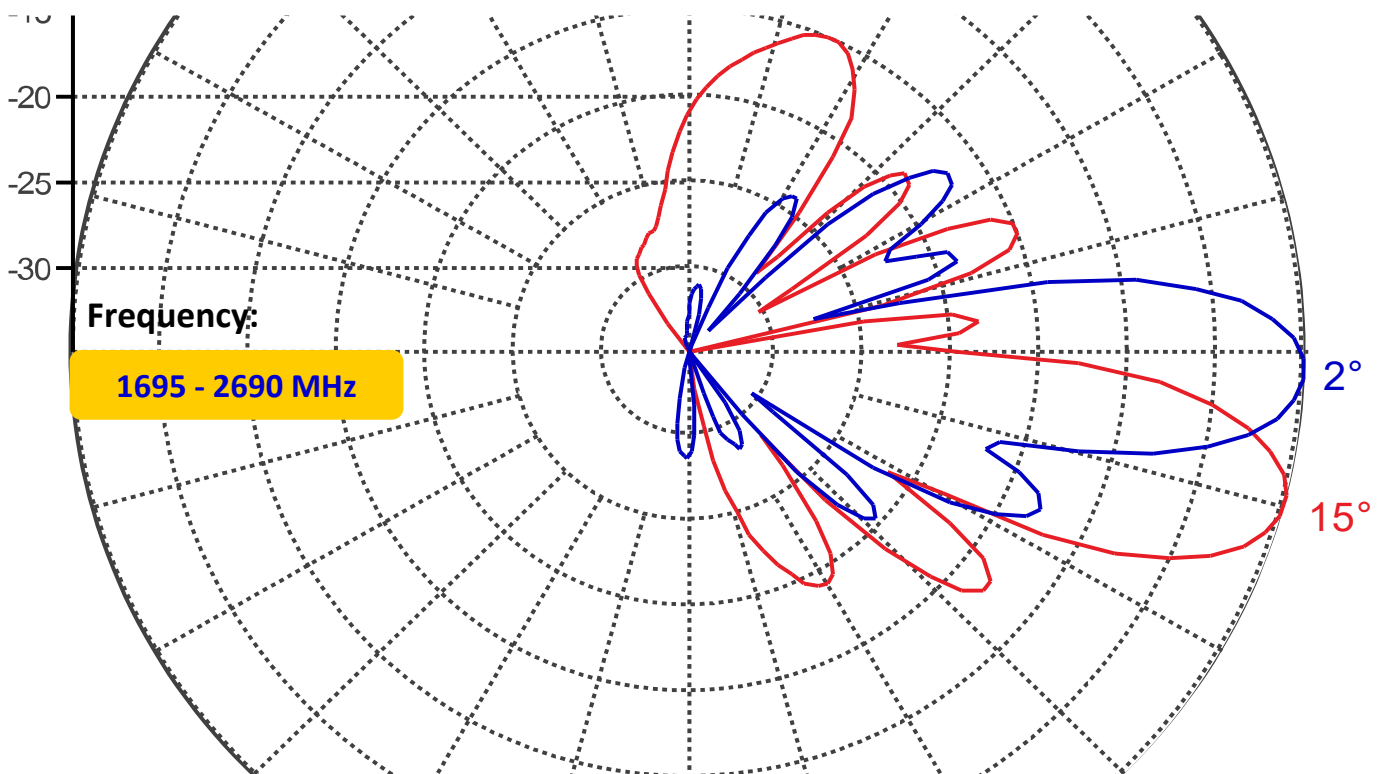

2.00 Beams and connectors

2.10 Plan view resultant beam layout

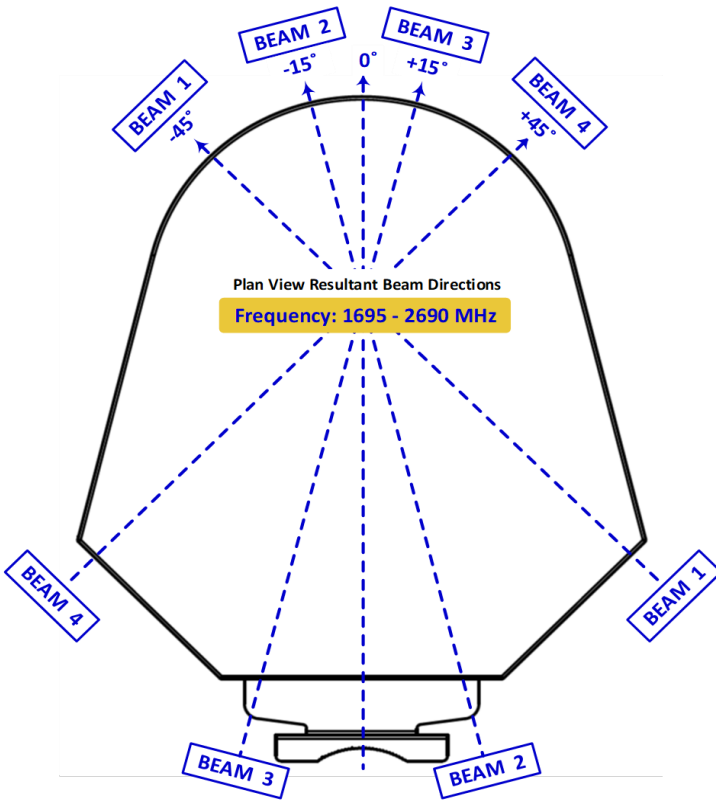

2.20 Connector port table

BEAM 1			
Port 3 (+45°)	Port 4 (-45°)	Port 1 (+45°)	Port 2 (-45°)
BEAM 2			
Port 7 (+45°)	Port 8 (-45°)	Port 5 (+45°)	Port 6 (-45°)
BEAM 3			
Port 11 (+45°)	Port 12 (-45°)	Port 9 (+45°)	Port 10 (-45°)
BEAM 4			
Port 15 (+45°)	Port 16 (-45°)	Port 13 (+45°)	Port 14 (-45°)

2.30 Connector detail

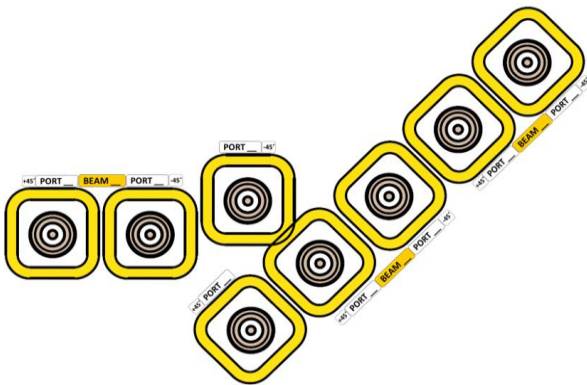

2.40 Connector layout

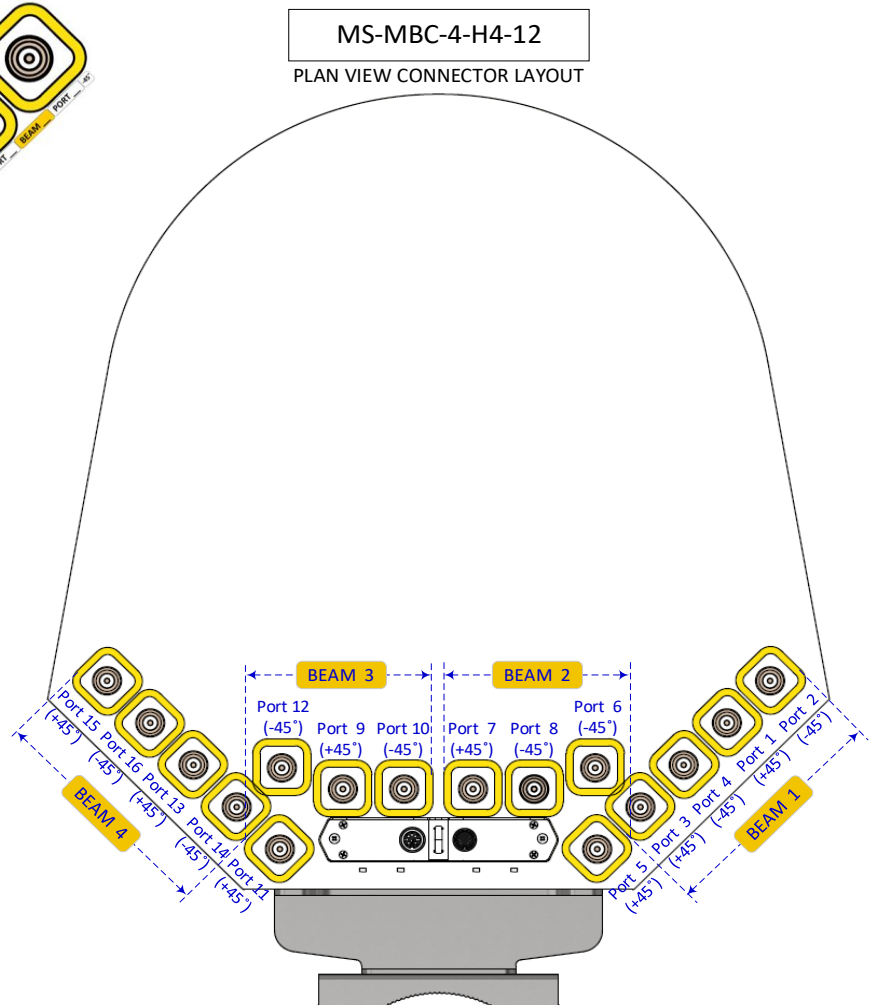

3.00 RET Operations and information

A standard AISG 2.0-compliant cable (not included) is used to connect the MDCU to the AISG interface control. Once connected, use an AISG 2.0-compliant control software to perform a subunit SCAN to identify the RET elements.

3.10 Example of serial numbers label reference



Model No. : MS-MBC-4-H4-12
 Serial No. : MS-MBC-4-H4-120002
 Frequency: 1695 - 2690 MHz

RET Controller Serial #
 MBC4H4120002H1
 MBC4H4120002H2
 MBC4H4120002H3
 MBC4H4120002H4

Delete a zero in front if the serial number is more than 4 digits.

Reminder: If information has been edited, remember to perform a "radio hard reset" for changes to take place.

3.11 Controller display

ALD List													
NO	HDLCL	Vendor	Serial Number	Product Number	H/W Version	S/W Version	3GPP	Device	AISG	Connect	Link		
1	1	MS	MBC4H4120002H1	9782.00A	5.04	5.0.4	6	Single RET	2	Connect	Link		
2	2	MS	MBC4H4120002H2	9782.00A	5.04	5.0.4	6	Single RET	2	Connect	Link		
3	3	MS	MBC4H4120002H3	9782.00A	5.04	5.0.4	6	Single RET	2	Connect	Link		
4	4	MS	MBC4H4120002H4	9782.00A	5.04	5.0.4	6	Single RET	2	Connect	Link		

MBC4H4120002H1 (HB beam 1)
 MBC4H4120002H2 (HB beam 2)
 MBC4H4120002H3 (HB beam 3)
 MBC4H4120002H4 (HB beam 4)

Model s/no. 4 digits

3.12 Beam numbers and ports number display

RET ID : MSMBC4H4120002H1

RET Status and Control

Antenna Information List				BEAM 1			
NO	Sector ID	Ant Model	Ant Serial	Port 3 (+45°)	Port 4 (-45°)	Port 1 (+45°)	Port 2 (-45°)
1/1	Beam 1 (Port 1, 2, 3, 4)	MSMBC4H412	MSMBC4H412-0002				

RET ID : MSMBC4H4120002H2

RET Status and Control

Antenna Information List				BEAM 2			
NO	Sector ID	Ant Model	Ant Serial	Port 7 (+45°)	Port 8 (-45°)	Port 5 (+45°)	Port 6 (-45°)
1/1	Beam 2 (Port 5, 6, 7, 8)	MSMBC4H412	MSMBC4H412-0002				

RET ID : MSMBC4H4120002H3

RET Status and Control

Antenna Information List				BEAM 3			
NO	Sector ID	Ant Model	Ant Serial	Port 11 (+45°)	Port 12 (-45°)	Port 9 (+45°)	Port 10 (-45°)
1/1	Beam 3 (Port 9, 10, 11, 12)	MSMBC4H412	MSMBC4H412-0002				

RET ID : MSMBC4H4120002H4

RET Status and Control

Antenna Information List				BEAM 4			
NO	Sector ID	Ant Model	Ant Serial	Port 15 (+45°)	Port 16 (-45°)	Port 13 (+45°)	Port 14 (-45°)
1/1	Beam 4 (Port 13, 14, 15, 16)	MSMBC4H412	MSMBC4H412-0002				

4.00 Bracket installation

4.10 Bolts and nuts / Tools

4.11 Bolts and nuts



4.12 Bracket



Bracket Qty	Bolts		Nuts	
	Size	Qty	Size	Qty
2	M12 x 200mm	4	M12	10

4.20 Tools requirement

4.21 Adjustable spanner

4.22 M12 spanner



4.30 Bracket spacing and installation sample

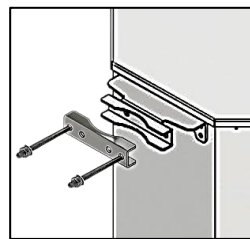
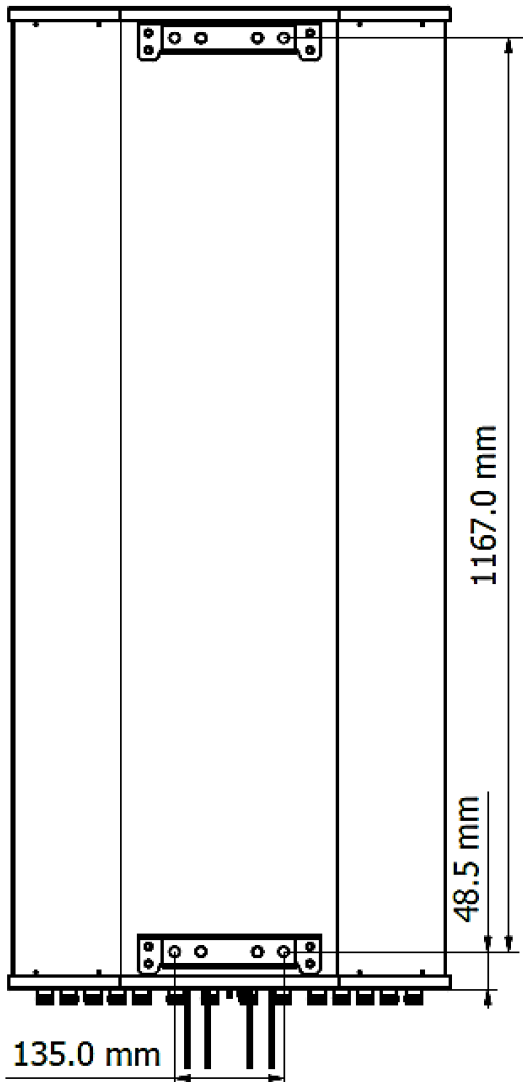

Before installation

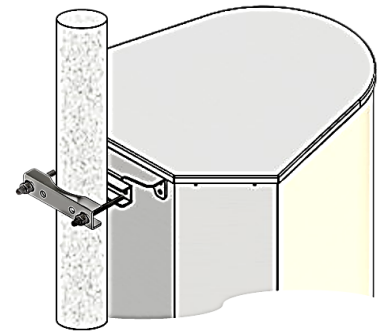

After installation

