

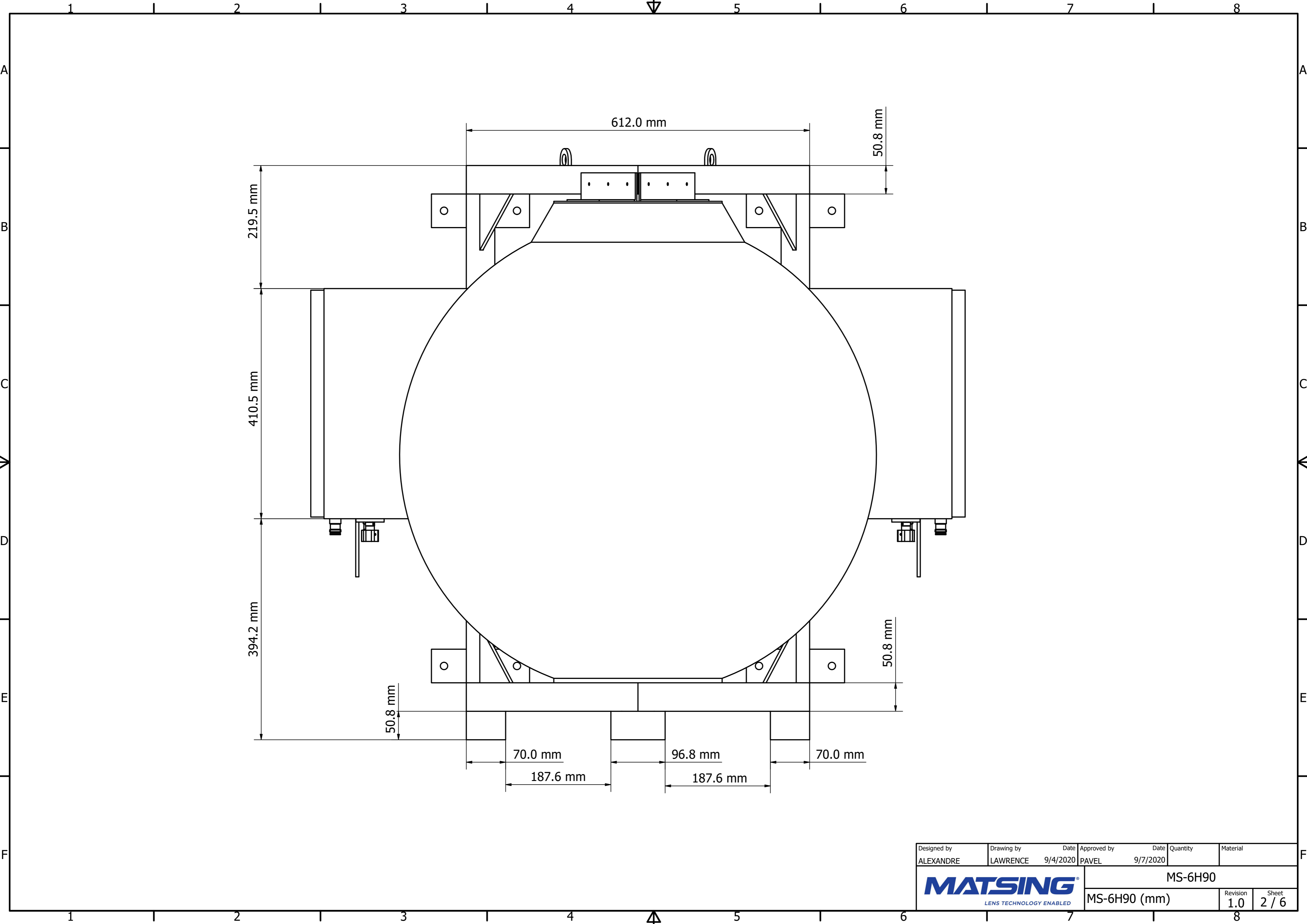

Designed by ALEXANDRE	Drawing by LAWRENCE	Date 9/4/2020	Approved by PAVEL	Date 9/7/2020	Quantity	Material
MATSING LENS TECHNOLOGY ENABLED						MS-6H90
MS-6H90 (mm)					Revision 1.0	Sheet 1 / 6



Designed by ALEXANDRE	Drawing by LAWRENCE	Date 9/4/2020	Approved by PAVEL	Date 9/7/2020	Quantity	Material
						MS-6H90
						MS-6H90 (mm)

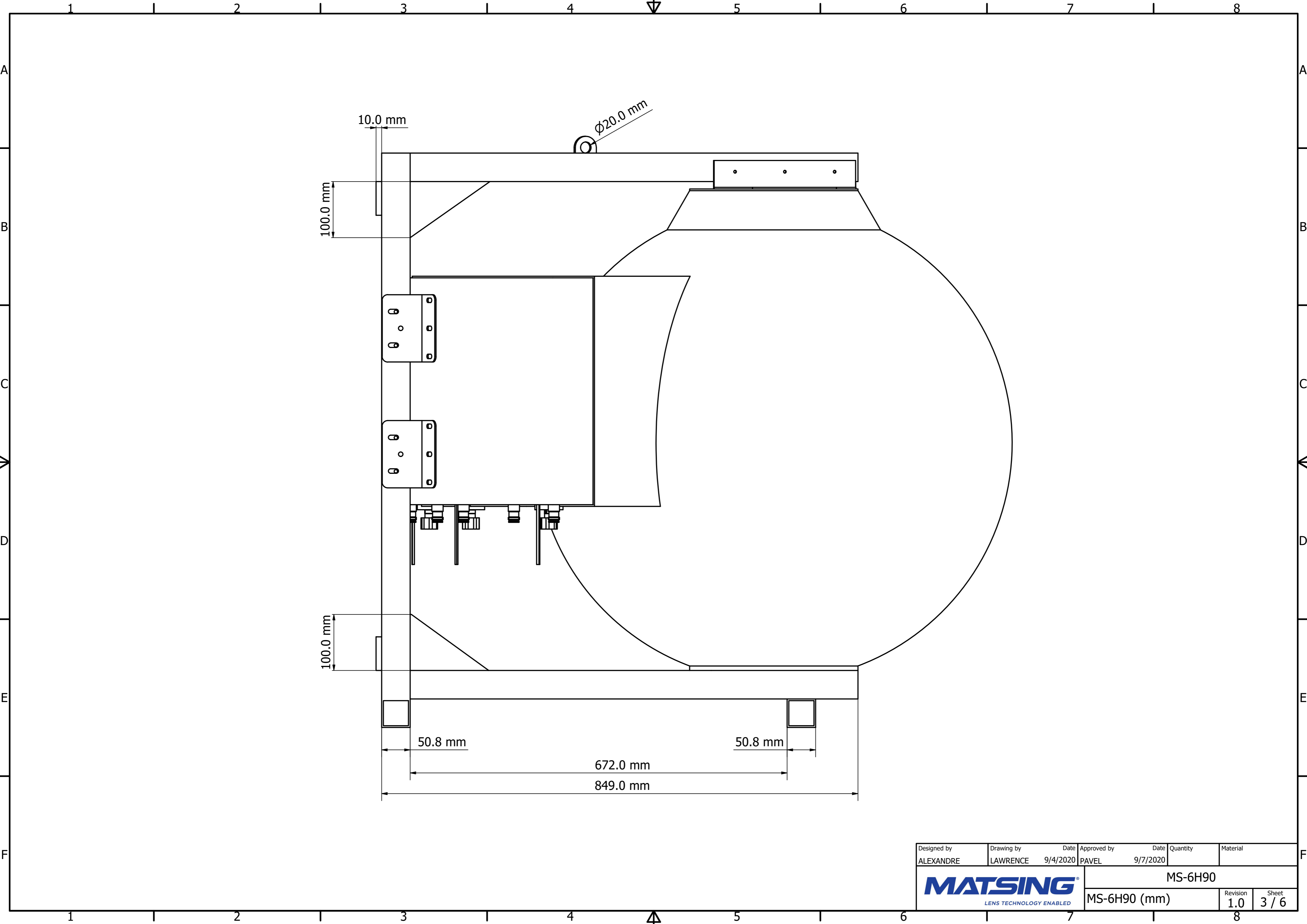

Designed by ALEXANDRE	Drawing by LAWRENCE	Date 9/4/2020	Approved by PAVEL	Date 9/7/2020	Quantity	Material
MATSING LENS TECHNOLOGY ENABLED						MS-6H90
MS-6H90 (mm)					Revision 1.0	Sheet 3 / 6

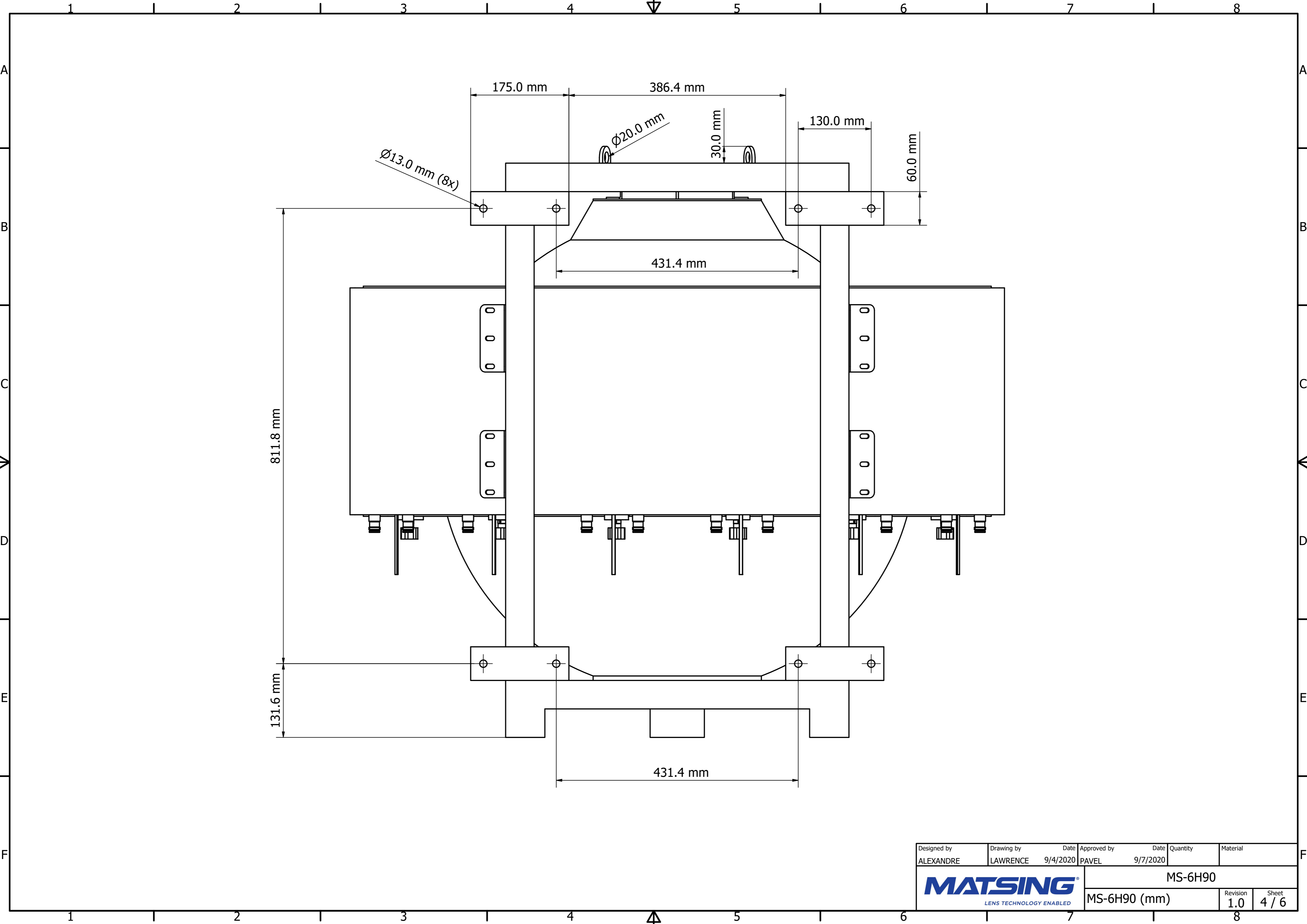

Designed by ALEXANDRE	Drawing by LAWRENCE	Date 9/4/2020	Approved by PAVEL	Date 9/7/2020	Quantity	Material
MATSING LENS TECHNOLOGY ENABLED						MS-6H90
MS-6H90 (mm)					Revision 1.0	Sheet 4 / 6

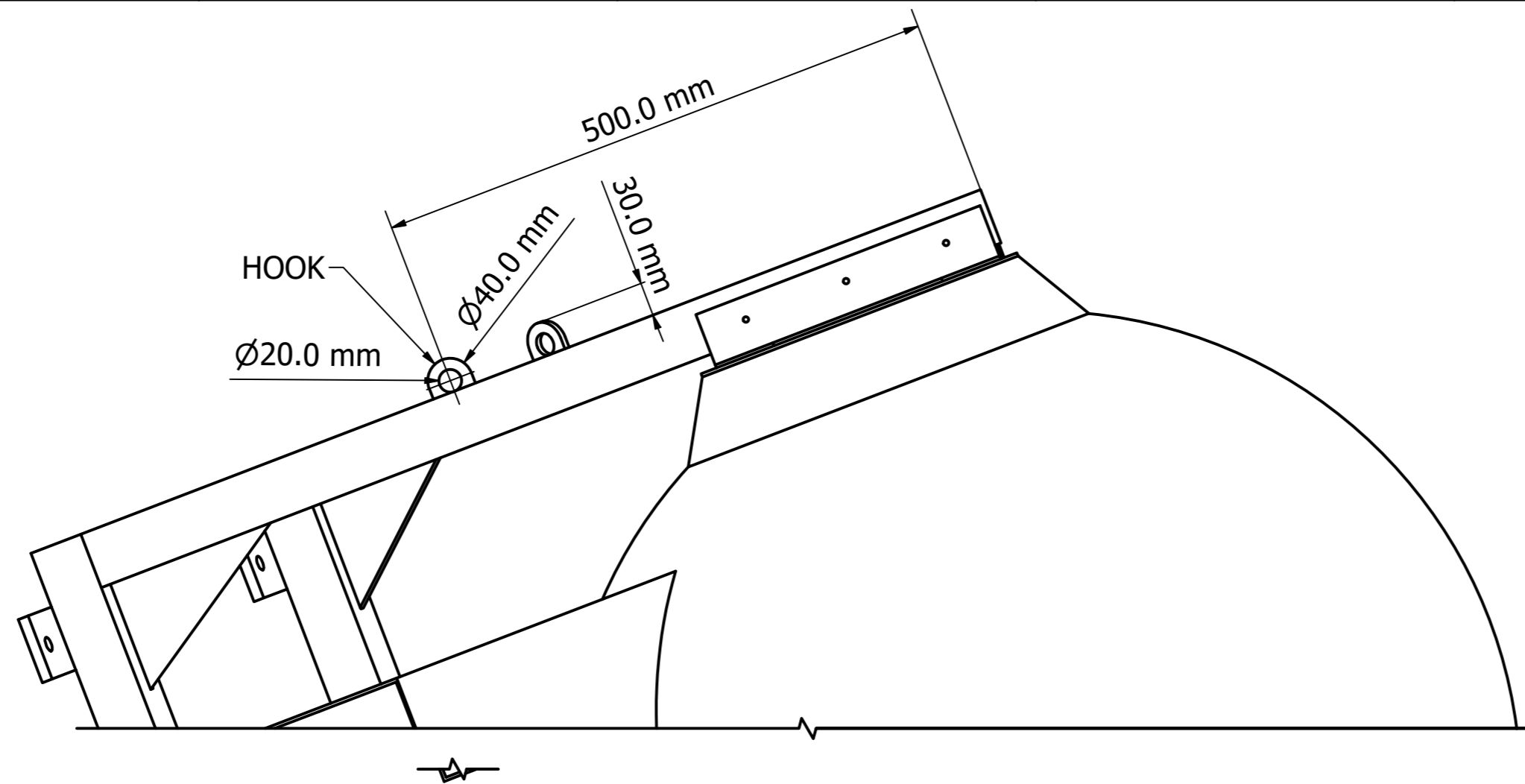

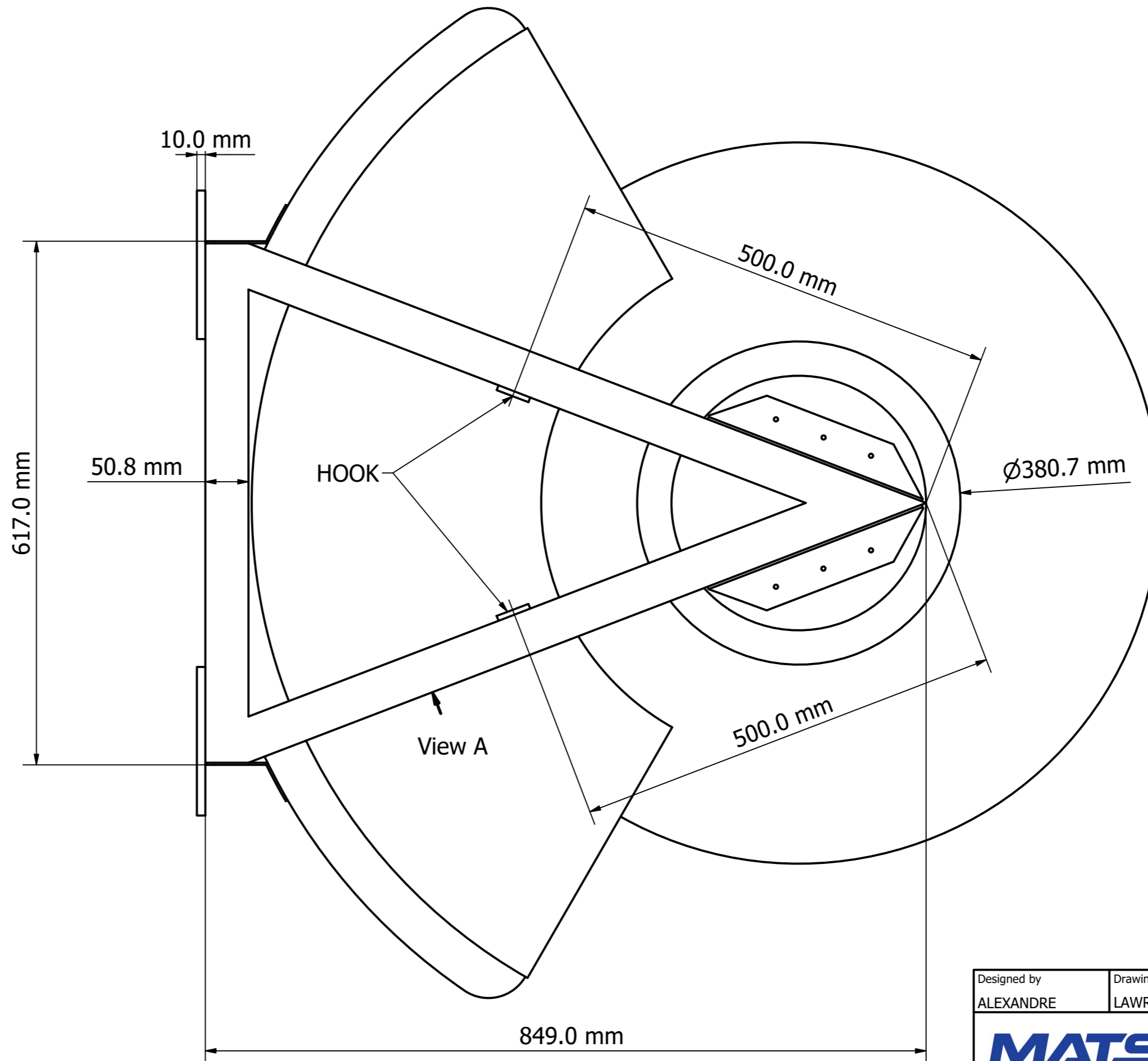

View A

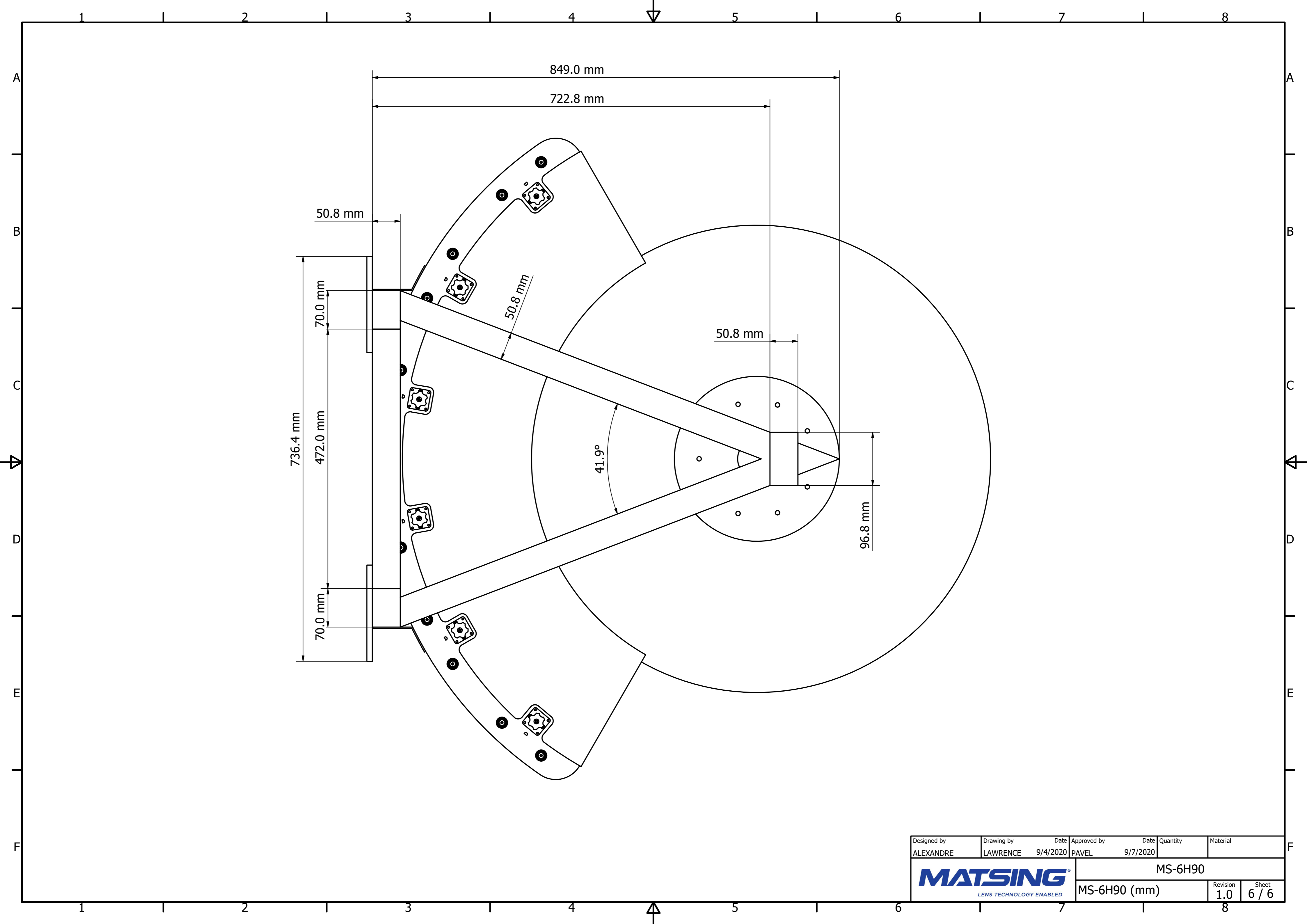

View A

Designed by ALEXANDRE	Drawing by LAWRENCE	Date 9/4/2020	Approved by PAVEL	Date 9/7/2020	Quantity	Material
						MS-6H90
						MS-6H90 (mm)



Designed by ALEXANDRE	Drawing by LAWRENCE	Date 9/4/2020	Approved by PAVEL	Date 9/7/2020	Quantity	Material
						MS-6H90
						MS-6H90 (mm)