

MS-3.3-F4

RF Lens based high performance and wide band antenna solution for stadiums, arenas and large venue applications where sidelobe and back lobe suppression is critical. CBRS band (3300-4200MHz) antenna with 3 beams, 4 ports per beam supporting 4X4 MIMO. This antenna provides a significant increase in capacity and number of sectors (>2X) when upgrading from traditional antenna technology.

Antenna Footprint (All Beams):

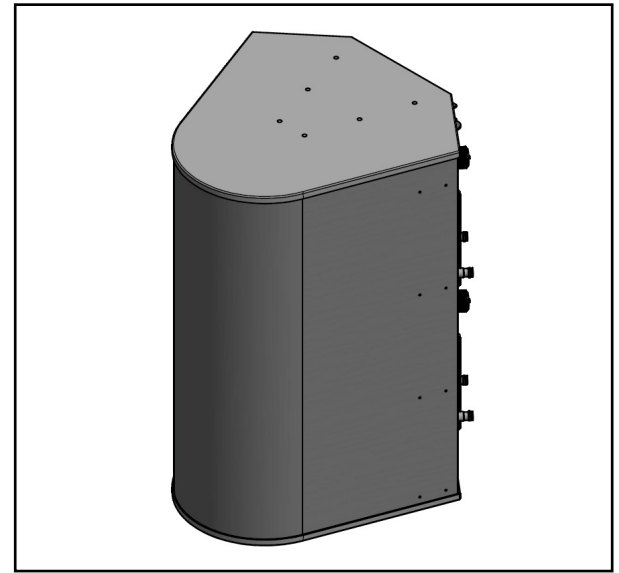
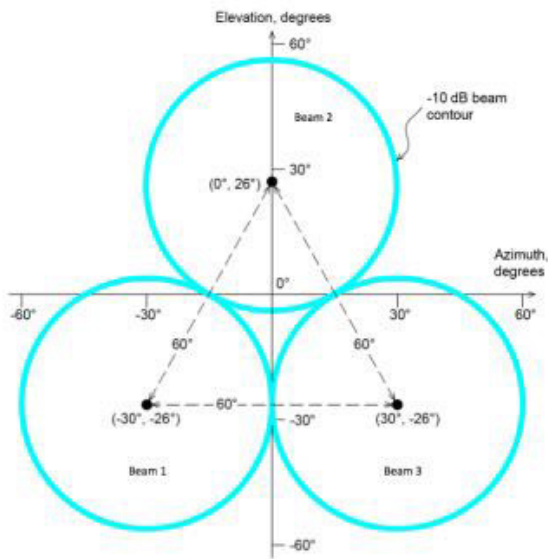

PATTERN RESULTS:

CBRS-Band Horizontal / Vertical Pattern (3.5GHz):

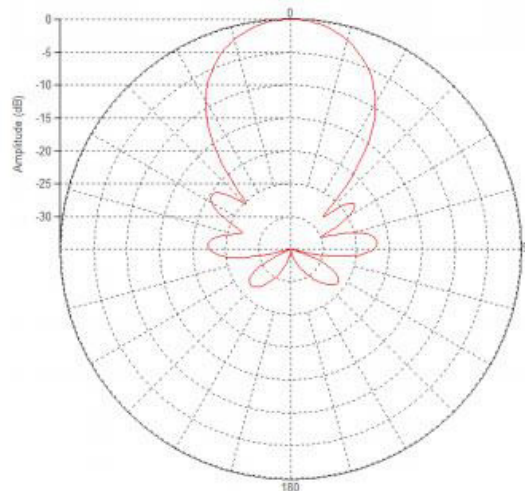

TECHNICAL SPECIFICATIONS

Frequency	3300 - 4200 MHz
Gain	13.5dBi
VSWR	<1.5:1
Return Loss	>15dB
Polarization	Dual Slant ±45°
Horizontal Coverage	60°
Horizontal / Vertical Beamwidth (10dB)	60°
Vertical / Vertical Beamwidth (3dB)	36°
Beam Cross-over	10dB typical
Total Number of Beams	3
Number of Ports per Beam	4
Number of Ports Total	12
First Sidelobe level	<-16dB
Front to Back Ratio	>25dB
Isolation Port to Port - Polarization	>28dB
Power Rating	100W per port
Intermodulation	<-153dBc
Impedance	50 ohm
Connector Quantity and Type	12 X 4.3-10 female

MECHANICAL DATA

Dimensions (H x W x D)	45 x 20 x 20 cm 18 x 8 x 8 inch
Antenna Weight	5kg 11lbs
Radome Material	Fiber Glass
Mounting	2 position pipe mount Compatible pipe diameter: 6.1 – 11.4 cm 2.4 – 4.5 inch

ENVIRONMENTAL RATINGS

Humidity	95% RH @ +30°C
Temperature	-40°C to +70°C
Wind load @ 150km/h	Frontal: 280 N / 63 lbf Lateral: 403 N / 90 lbf

CONNECTOR LAYOUT:

