

MS-24C180

Multi-Beam C-Band Spherical Lens Antenna: 1 row of 24 dual-polarized beams, with independent 0° - 15° tilt per beam.

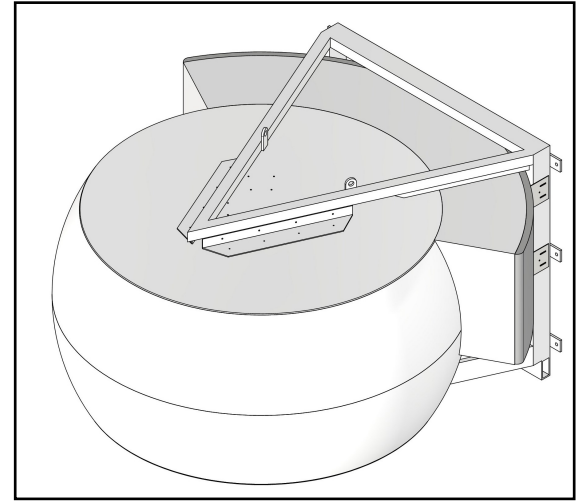

PATTERN RESULTS: (3.9GHz)

Horizontal Pattern

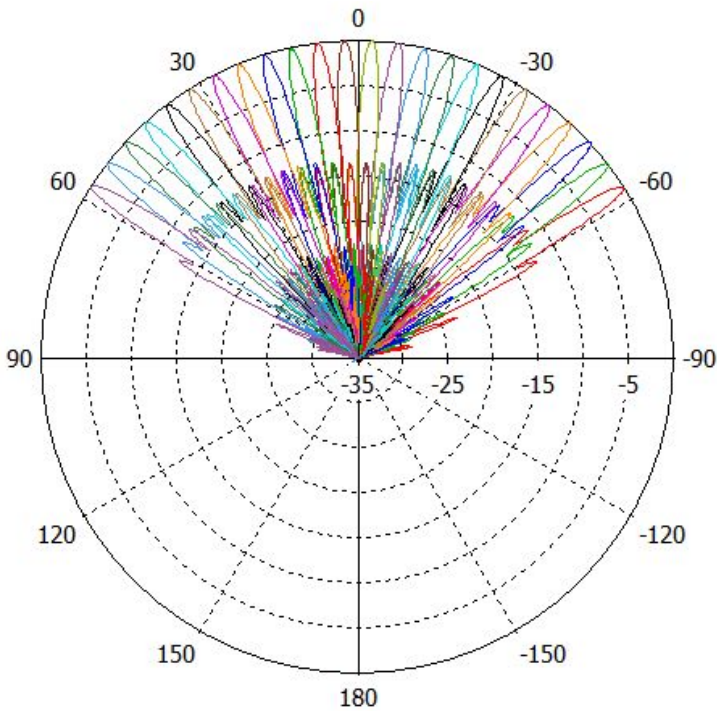

Vertical Pattern 0° tilt

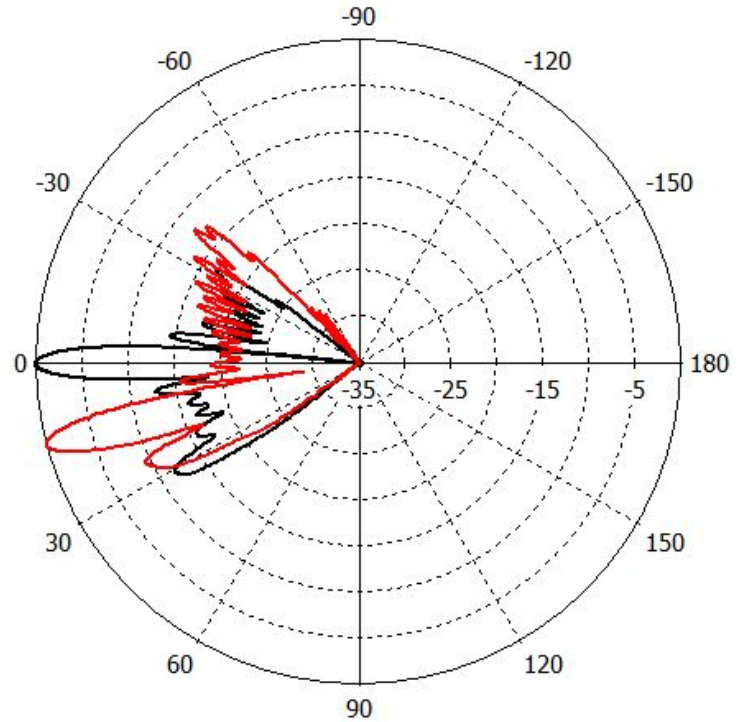

TECHNICAL SPECIFICATIONS

Frequency	3.7 - 4.2 GHz
Gain	30dBi
VSWR	<1.5:1
Polarization	Dual Slant ±45°
Horizontal Coverage	120°
Horizontal Beamwidth (10dB level)	5°
Horizontal Beamwidth (3dB level)	3°
Vertical Beamwidth (10dB level)	9°
Vertical Beamwidth (3dB level)	5°
Beam Cross-over	10dB typical
Total Number of Beams	24
RET	0° to 15°
First Sidelobe level	<-16dB
Front to Back Ratio	>28dB
Isolation Port to Port - Polarization	>28dB
Isolation Port to Port - Beam	>28dB
Power Rating	50W per port
Intermodulation	<-153dBc
Impedance	50 ohm
Connector Quantity and Type	48 X 4.3-10 female

MECHANICAL DATA

Dimensions (H x W x D)	Spherical Lens diameter: 180cm/70inch Antenna dimensions: 119.8 x 202.6 x 207 cm 47.2 x 79.8 x 81.5 inch
Antenna Weight	220 kg 485 lbs
Radome Material	Fiber Glass
Mounting	2 position pipe mount Compatible pipe diameter: 6.1 – 11.4 cm 2.4 – 4.5 inch

ENVIRONMENTAL RATINGS

Humidity	95% RH @ +30°C
Temperature	-40°C to +70°C
Wind load @ 150 km/hr	N/lbf Frontal: 1548/348 Lateral: 1548/348 Rear: 1548/348

CONNECTOR LAYOUT:

