

MATSING®

LENS TECHNOLOGY ENABLED

MS-12H90

Multi-Beam Wide Band Spherical Lens Antenna: 2 rows of 6 independent high frequency (1695-2690MHz) cross-polarized beams. Top and bottom row have independent 15° tilt.

BEAM LAYOUT:

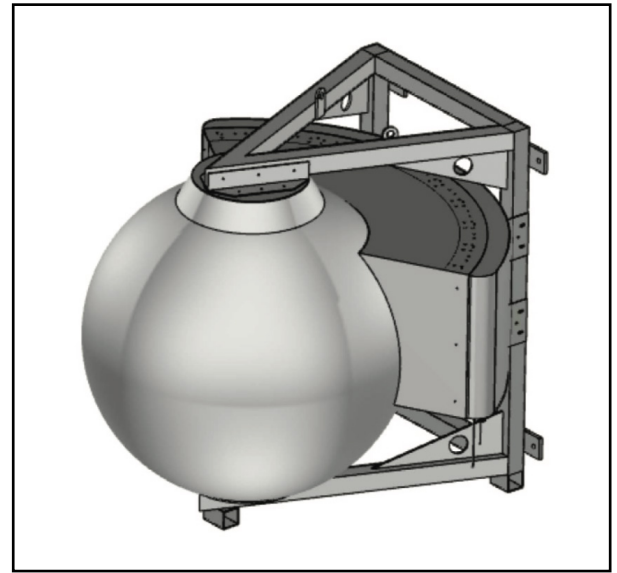
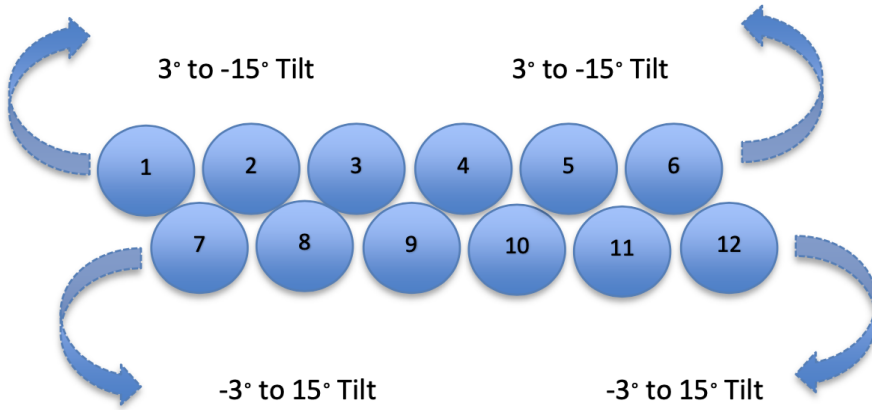

PATTERN RESULTS:

Horizontal Pattern top row

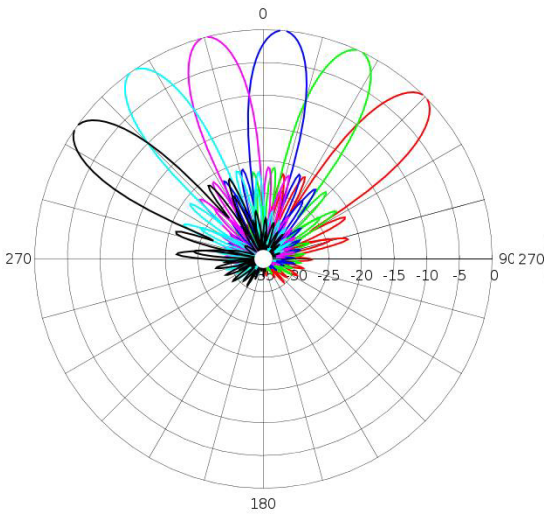

Horizontal Pattern bottom row

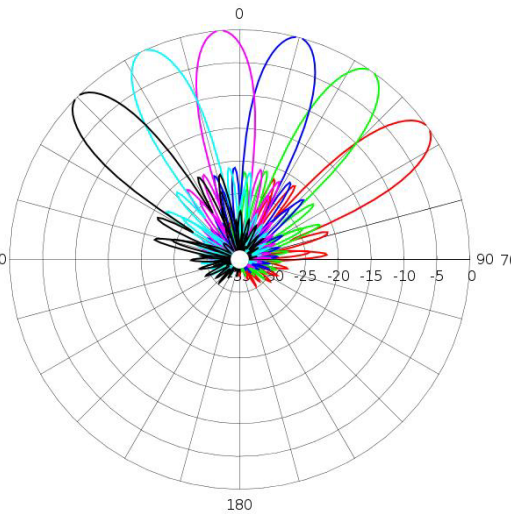

Vertical Pattern

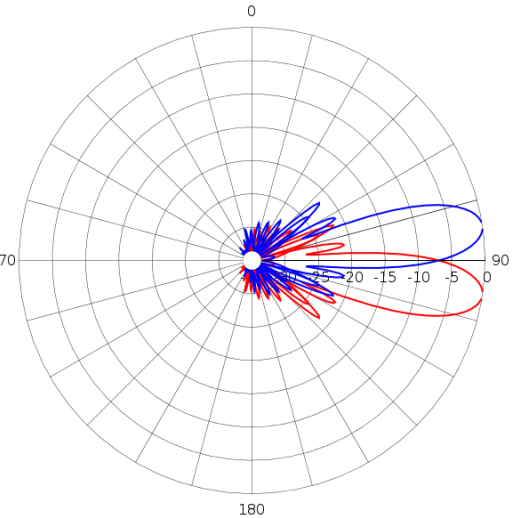

TECHNICAL SPECIFICATIONS PER BEAM

Frequency	1695-2690 MHz
Gain	22.5dBi
VSWR	<1.5:1
Polarization	Dual Slant ±45°
Horizontal Coverage	120°
Horizontal Beamwidth (10dB level)	20°
Horizontal Beamwidth (3dB level)	12°
Vertical Beamwidth (10dB level)	20°
Vertical Beamwidth (3dB level)	12°
Beam Cross-over	10dB typical
Total Number of Beams	12
Tilt ≥12° beam separation required between the two rows	3° to -15° upper row -3° to 15° lower row
First Sidelobe level	<-16dB
Front to Back Ratio	>28dB
Isolation Port to Port - Polarization	>28dB
Isolation Port to Port - Beam	>28dB
Power Rating	200W per port
Intermodulation	<-153dBc
Impedance	50 ohm
Connector Quantity and Type	24 x 4.3-10 female

MECHANICAL DATA

Dimensions (H x W x D)	Spherical Lens diameter: 90cm/35inch Antenna dimensions: 105.4 X 122.4 X 114.5 cm 41.5 X 48.2 X 45.1 inch
Antenna Weight	58.8 kg 129.8 lbs
Radome Material	Fiber Glass
Mounting	Standard Pipe Mount Compatible pipe diameter: 6.1 – 11.4 cm 2.4 – 4.5 inch

ENVIRONMENTAL RATINGS

Humidity	95% RH @ +30°C
Temperature	-40°C to +70°C
Wind load	754N @ 160km/h 170lbf @ 160km/h

CONNECTOR LAYOUT:

