

MS-12.6DB180

Multi-Beam Dual Band Spherical Lens Antenna: 6 independent low frequency (698-960MHz) cross-polarized beams and 12 independent high-frequency (1695-2690MHz) cross-polarized beams, with 0-15° tilt for each 20° sector and 2X2 MIMO support. Sector consists of 1 low-band beam and 2 high-band beams.

External RET Controller MS-EXT-RET-12.6 Option available

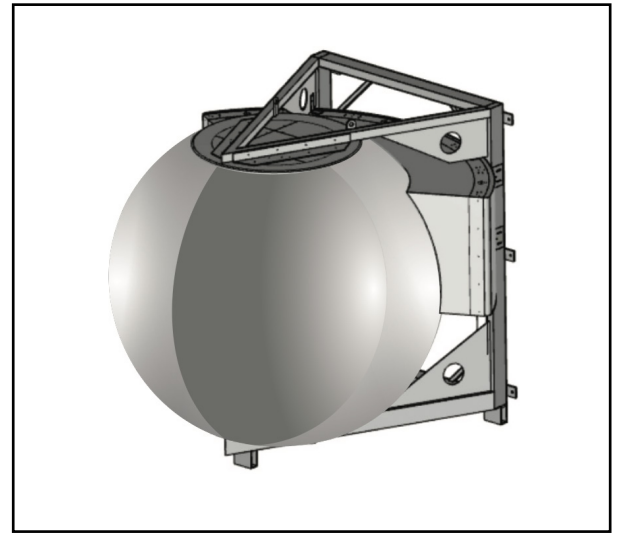

PATTERN RESULTS:

High-Band Horizontal Pattern (1.80GHz)

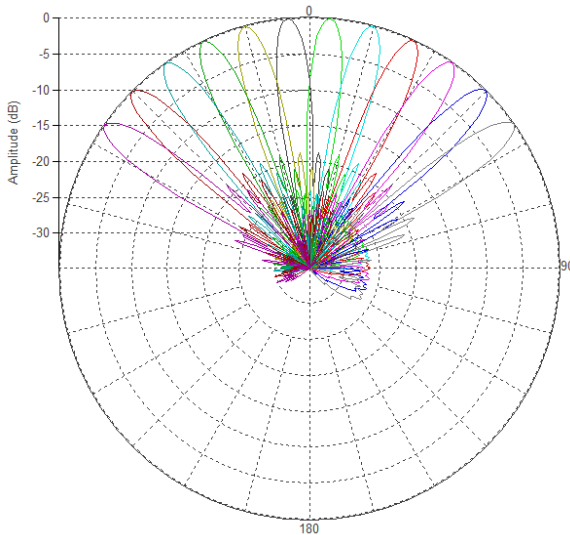

High-Band Vertical pattern (1.80GHz)

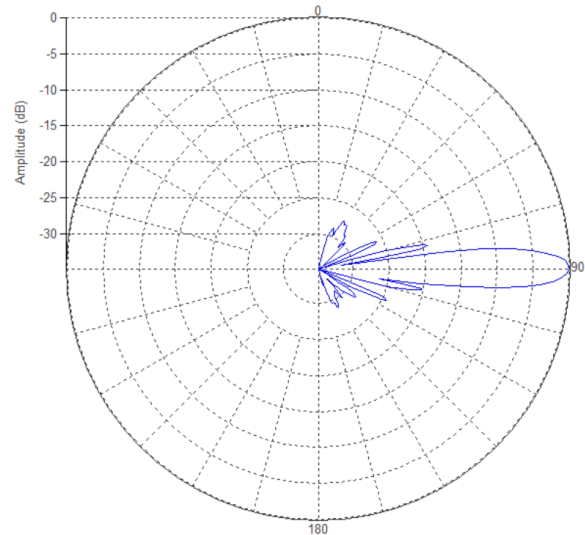

Low-Band Horizontal Pattern (0.85GHz)

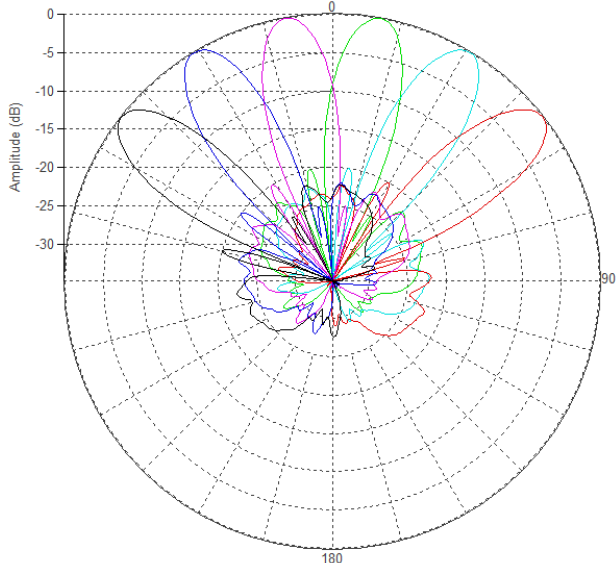

Low-Band Vertical Pattern (0.85GHz)

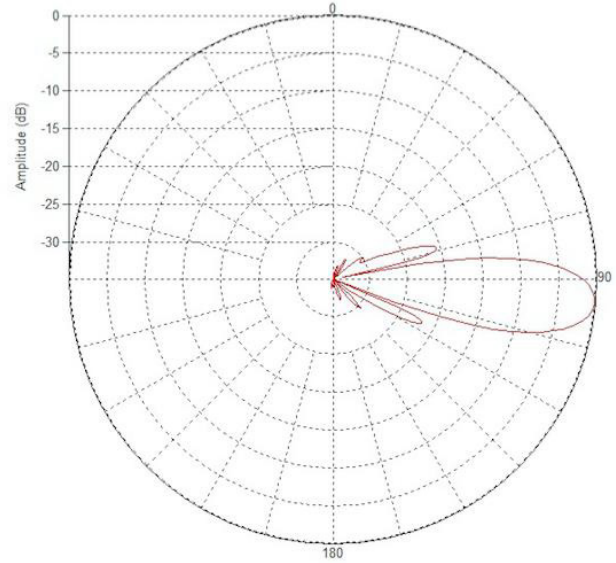

TECHNICAL SPECIFICATIONS PER BEAM

Frequency	698-960 MHz	1695-2690 MHz
Gain	20.5dBi	27.5dBi
VSWR	<1.5:1	<1.5:1
Polarization	Dual Slant ±45°	Dual Slant ±45°
Horizontal Coverage	120°	120°
Horizontal Beamwidth (10dB level)	20°	10°
Horizontal Beamwidth (3dB level)	12°	6°
Vertical Beamwidth (10dB level)	20°	10°
Vertical Beamwidth (3dB level)	12°	6°
Beam Cross-over	10dB typical	10dB typical
Total Number of Beams	6	12
Manual Adjustable Tilt per 20° sector (each sector having 2 high-band beams and 1 low-band beam)	5° to 20°	0° to 15°
First Sidelobe level	<-15dB	<-16dB
Front to Back Ratio	>28dB	>28dB
Isolation Port to Port - Polarization	>28dB	>28dB
Isolation Port to Port - Beam	>26dB	>28dB
Power Rating	250W per port	250W per port
Total Applied Power	≤ 2.5KWatts	
Intermodulation	<-153dBc	<-153dBc
Impedance	50 ohm	50 ohm
Connector Quantity and Type	12 X 4.3-10 female	24 X 4.3-10 female

MECHANICAL DATA

Dimensions (H x W x D)	Spherical Lens diameter: 180cm/70inch Antenna dimensions: 187.1 X 207 X 204.4 cm 73.7 X 81.5 X 80.5 inch
Antenna Weight	247.6 kg 545.9 lbs
Radome Material	Fiber Glass
Mounting	Adjustable Clamps Compatible pipe diameter: 6.1 – 11.4 cm 2.4 – 4.5 inch

ENVIRONMENTAL RATINGS

Humidity	95% RH @ +30°C
Temperature	-40°C to +70°C
Wind load @ 150 km/h	N/lbf Frontal: 1892/425 Lateral: 2053/462

CONNECTOR LAYOUT:

