

MS-12C90

Multi-Beam Wide Band Spherical Lens Antenna: 1 row of 12 independent C-Band (3700-4200MHz) cross-polarized beams. Each beam has Fixed Tilt.

BEAM LAYOUT:

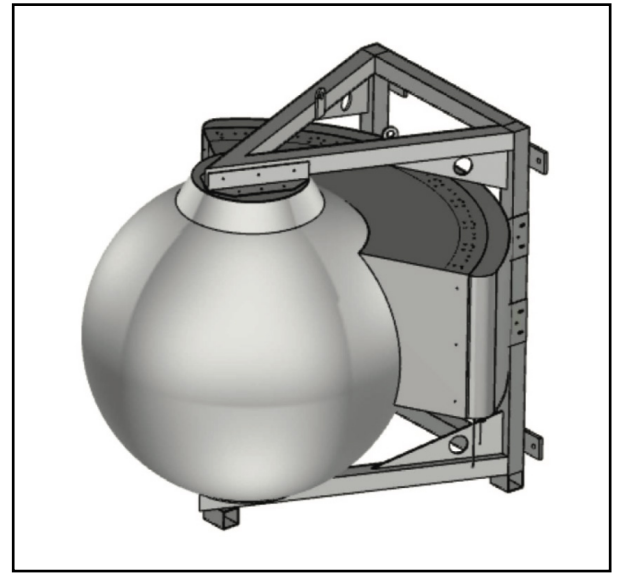

PATTERN RESULTS:

Horizontal Pattern (3.95GHz)

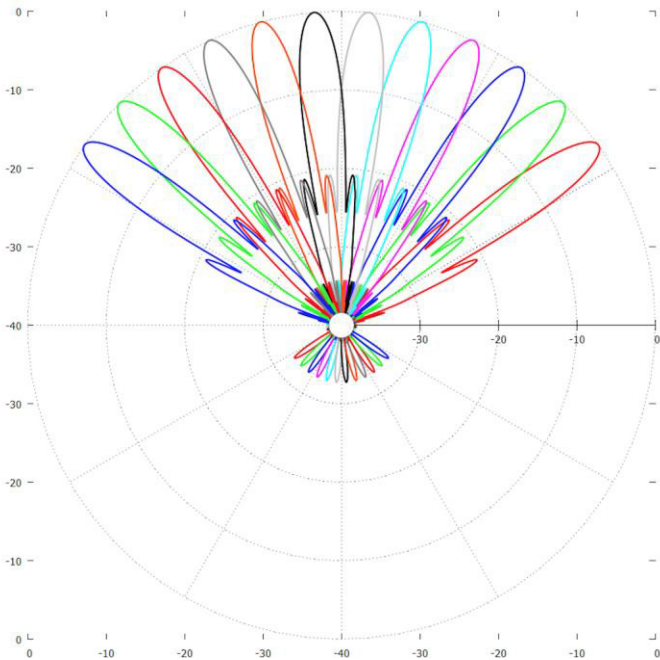

Vertical Pattern (3.95GHz) 0° Tilt

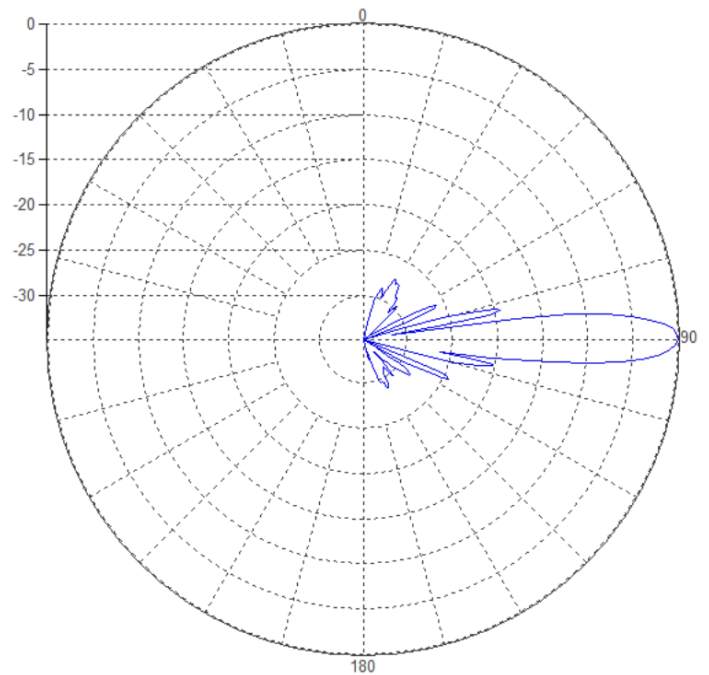

TECHNICAL SPECIFICATIONS PER BEAM

Frequency	3700 - 4200 MHz
Gain	28.5dBi
VSWR	<1.5:1
Polarization	Dual Slant ±45°
Horizontal Coverage	120°
Horizontal Beamwidth (10dB)	10°
Horizontal Beamwidth (3dB)	6°
Vertical Beamwidth (10dB)	10°
Vertical Beamwidth (3dB)	6°
Beam Cross-over	10dB typical
Total Number of Beams	12
Tilt	Fixed
First Sidelobe level	<-16dB
Front to Back Ratio	>28dB
Isolation Port to Port - Polarization	>28dB
Isolation Port to Port - Beam	>28dB
Power Rating	50W per port
Intermodulation	<-153dBc
Impedance	50 ohm
Connector Quantity and Type	24 X 4.3-10 female

MECHANICAL DATA

Dimensions (H x W x D)	Spherical Lens diameter: 90cm/35inch Antenna dimensions: 105.4 x 113.7 x 109.9 cm 41.5 x 44.8 x 43.3 inch
Antenna Weight	61.65kg 135.5lbs
Radome Material	Fiber Glass
Mounting	Standard position pipe mount Compatible pipe diameter: 6.1 – 11.4 cm 2.4 – 4.5 inch

ENVIRONMENTAL RATINGS

Humidity	95% RH @ +30°C
Temperature	-40°C to +70°C
Wind load @ 150km/h	Frontal 489 N / 110 lbf Lateral 543 N / 122 lbf

CONNECTOR LAYOUT:

